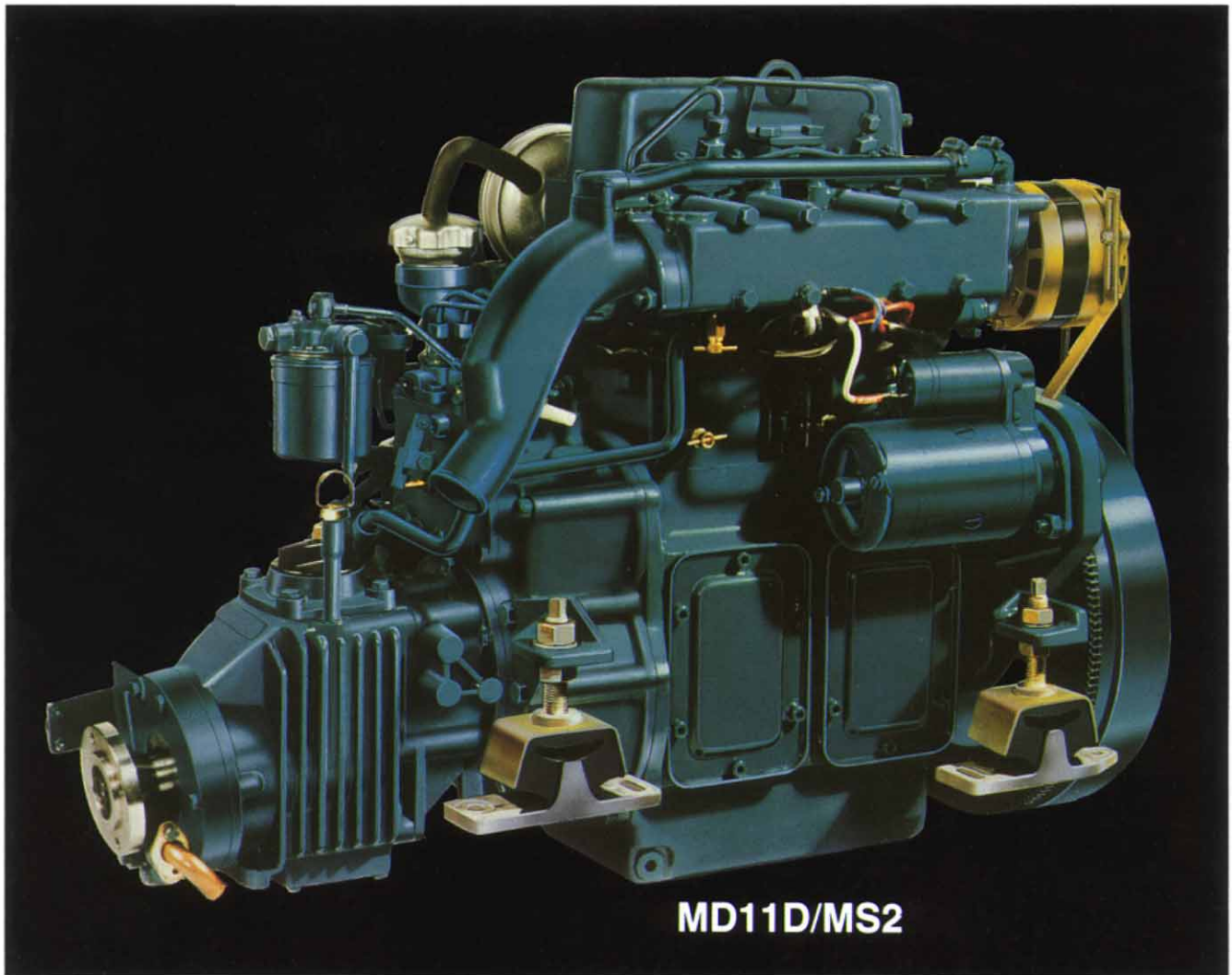

**VOLVO
PENTA****MD11D****MD11D/MS2**

2-cylinder marine diesel engine with direct injection Propeller shaft output, leisure craft – 18.4 kW (25 hp)

The new Volvo Penta MD11D with its higher speed (3.000 r/min) and greater output (25 hp) together with the latest and unique Volvo Penta transmission gives significant improvements in propeller thrust.

In practice this new combination means better manoeuvrability, better boat acceleration and, faster stopping plus reduced speed loss in heavy seas and high headwinds.

This robust purpose built marine engine with features like extra wall thickness in the cooling passages and replaceable cylinder liners makes the MD11D very resistant to corrosion and wear.

The very accurate fuel metering even at full throttle means extremely clean exhaust gasses and a miserly fuel consumption.

The new Volvo Penta MS2 reverse reduction gear has a slip coupling built in and easy shift cone clutch, features also found in the model 120 S-drive.

An experienced and strategically placed network of authorised Volvo Penta workshops ensures you of the best service and parts backup.

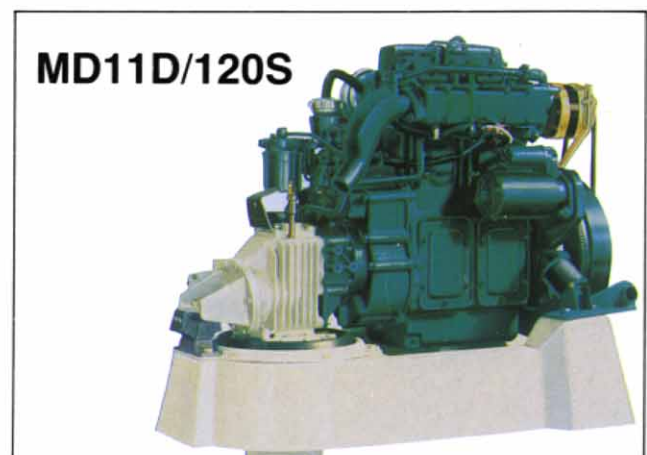
**MD11D/120S**
3000
SERIEN

MD11/MS2

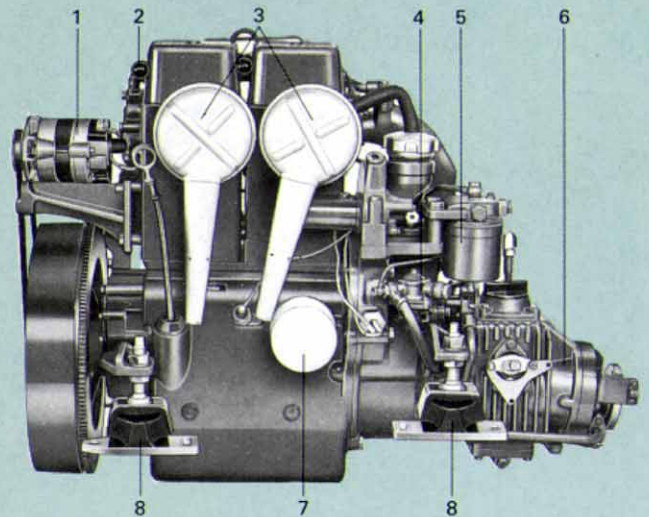
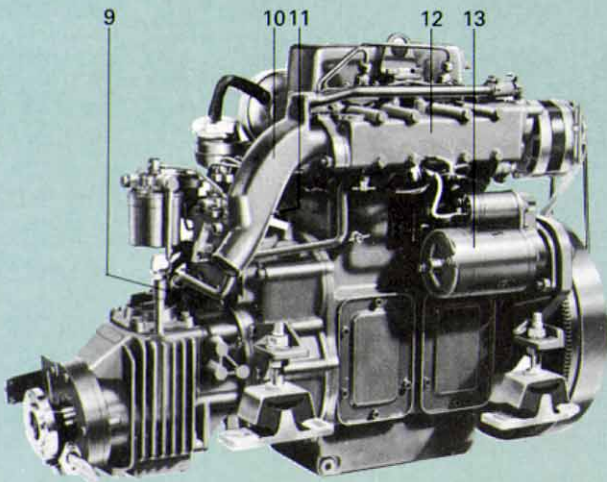

MD11/120S

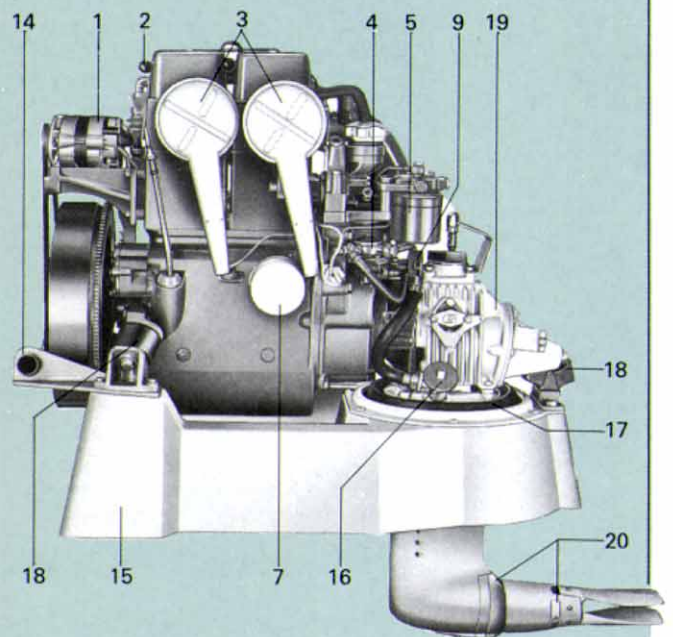
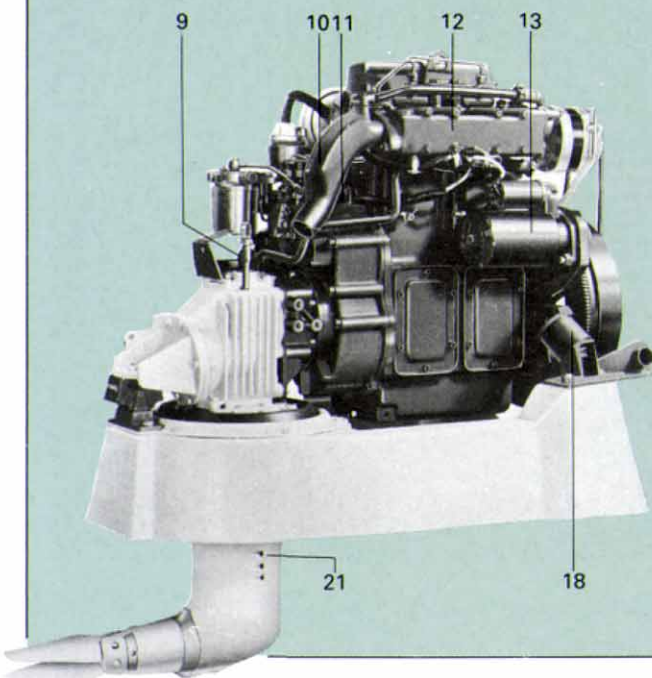

Standard equipment

ENGINE BODY

Separate engine blocks and cylinder heads of cast iron. Replaceable wet cylinder liners. 3-bearing crankshaft dimensioned for long service life.

FUEL SYSTEM

Injection pump with all-speed regulator (11), manual cold starting device, and stop lever with bracket for push-pull mechanism. Exchangeable fuel filter (5). Feed pump with hand primer (4). Flexible fuel suction hose (approved by DNV, LR, GL and BV) for copper pipe unions.

COOLING SYSTEM

Thermostatically controlled sea-water cooling. Sea-water pump (9)

with easily replaceable pump impeller.

LUBRICATING SYSTEM

Pressurized lubricating system with exchangeable oil filter (7). Closed-circuit crankcase ventilation.

INTAKE SYSTEM

Intake silencers (3) with cleanable air filters.

EXHAUST SYSTEM

Sea-water cooled exhaust manifold of cast iron (12). Exhaust manifold elbow (10) with coolant outlet for connection to rubber exhaust hose.

REVERSE REDUCTION GEAR

MS2 (6), ratio options 2.4:1 or

3.0:1. Sea-water cooled. Output shaft downward angle 7°. Supplied without propeller shaft flange.

DRIVE

Type 120S (19) ratio 2.2:1. Complete with rubber diaphragm, sealing ring and mounting collar (17) which fits to bed. Coolant inlet (21) in leg. Cock (16) for coolant. Sacrificial anode ring of zinc (20) to counteract corrosion.

ENGINE MOUNTING

Flexible mountings for optimal quiet and vibration-free running. MD11D/MS2 – Engine/reverse reduction gear has high-adjustable engine mounting brackets (8) complete with rubber blocks. MD11D/120S – S-drive for fitting directly to the engine. The engine/drive unit is insulated from the hull by a 3-point flexible mounting

system (18) and a rubber diaphragm (17).

Bed of glassfibre reinforced plastics (15). Engine movement limiter (14) prevents excessive movement should the drive touch bottom. (Drive 120S).

ELECTRICAL SYSTEM

12V corrosion-proof electrical system complete with instrumentation. Alternator (1) 50 A, 600 W, approved for marine use. Voltage regulator with fast-charge mode. Alternator prepared for retrofitting of twin diode kit which gives auto-

matic distribution of charge current to two or more batteries.

STARTING SYSTEM

Electric starter motor (13), output 0.8 kW (1.1 hp). Manual starting crank for extra security with decompression knob (2) for easier cranking.

INSTRUMENT PANEL

Complete with ignition key starter switch, tachometer, temperature gauge, warning lamps for charging and oil pressure and also switch for instrument lighting. Master fuse with built in spare fuses. Cable

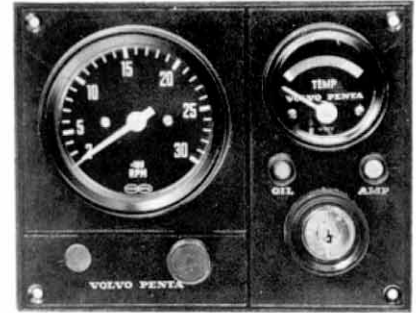

harness, length 4 m, with connector.

TOOL KIT

Sufficient for less extensive service work.

Data

Engine type	4-stroke diesel with direct injection
Propeller shaft output*	
MD11D/MS2, MD11D/120S	18.4 kW (25 hp at 3000 r/min)
No. of cylinders	2
Bore/stroke, mm (in)	88.9/90 (3.5/3.54)
Swept displacement volume, dm ³ (in ³)	1.12 (68.4)
Valve system	Top
Reverse reduction gear type MS2, ratio	2.4:1 or 3.0:1
Weight, engine with reverse/reduction gear approx. kg (lb)	221 (487)
Drive type 120S ratio	2.2:1
Weight, engine with drive approx. kg (lb)	238 (525)

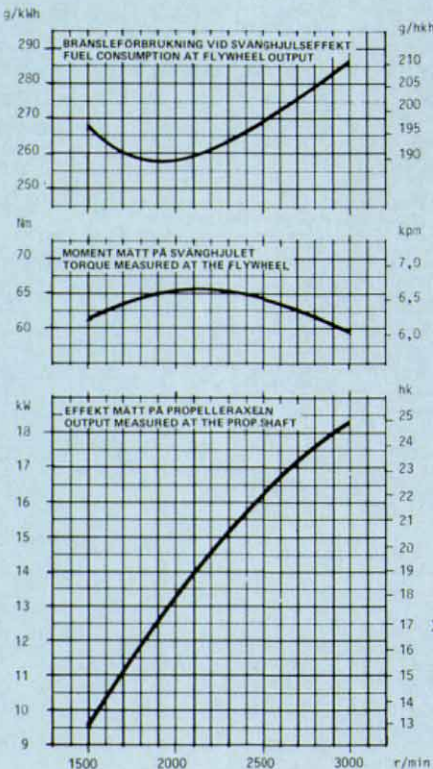

* The diagrams show propeller shaft output for a run-in engine and reverse reduction gear/drive as per DIN 6270 Leistung B für Dauerbetrieb.

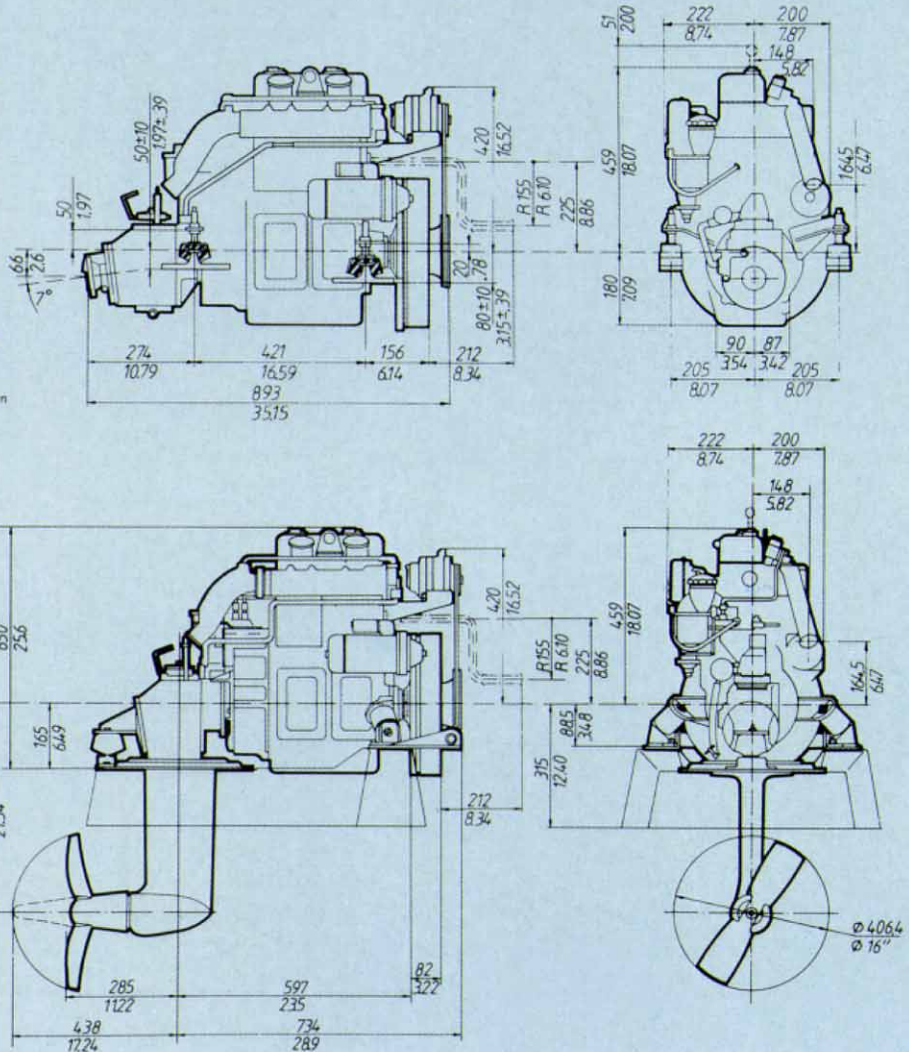

Reverse reduction gear MS2

Drive 120S

1. Easy access oil filler
2. Oil dipstick
3. Spiral bevel gears for quiet, efficient operation

4. Volvo Penta's patented cone clutch gives smooth quiet engagement of forward and reverse.
5. Output shaft with 7° downward angle. Horizontal installation of engine in less space.

6. Coolant pipe for oil cooling
7. All joints have stainless steel screws in stainless steel thread inserts

8. In-built slip coupling which safeguards against over-loading (for running aground) thereby protecting the transmission

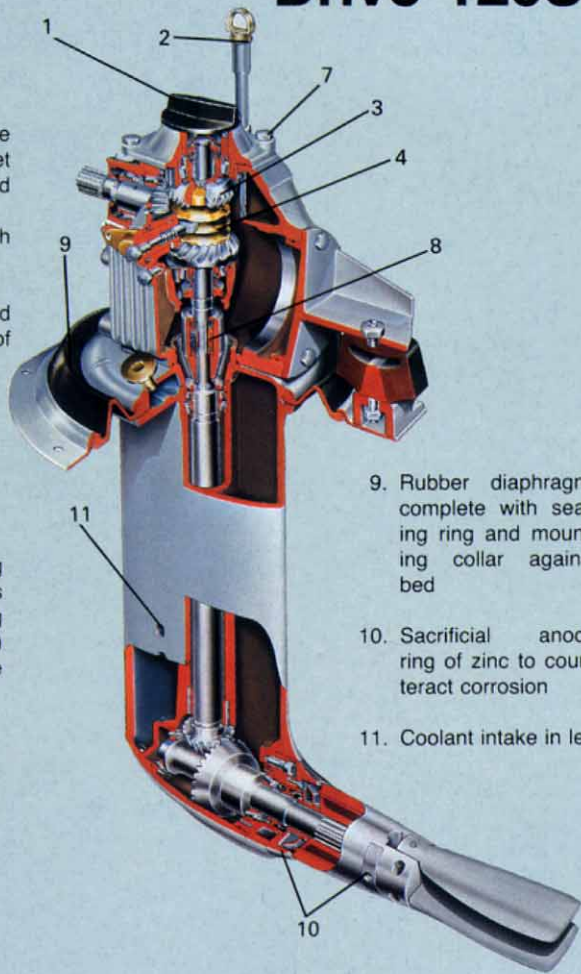
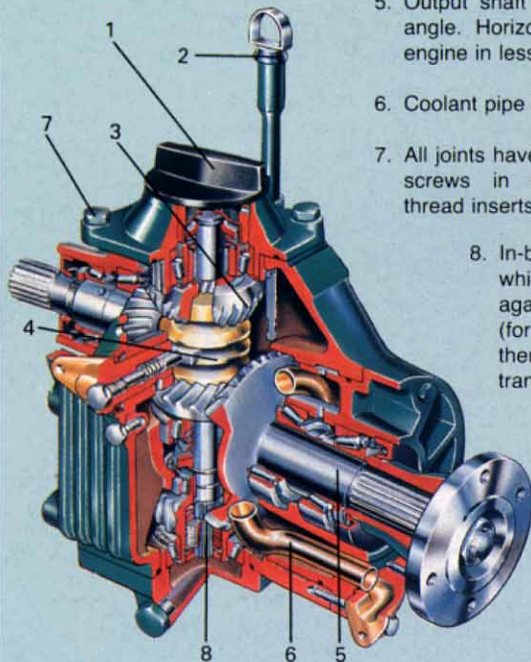

9. Rubber diaphragm, complete with sealing ring and mounting collar against bed
10. Sacrificial anode ring of zinc to counteract corrosion
11. Coolant intake in leg

Accessories

FUEL SYSTEM

Electric fuel pump.
 Mechanical cold starting device.
 Electric cold starting device.
 Water-trap and fine filter, with or without flexible hoses.
 Water trap.
 Fuel tank.
 Cap with union for supply from fuel tank.
 Copper fuel pipe kit complete with unions.

COOLING SYSTEM

Fresh water cooling.
 Sea-water filter, complete with mountings.
 Vacuum valve.

EXHAUST SYSTEM

Rubber exhaust hose.
 Hull passthrough for exhaust pipe.
 Water-cooled silencer, complete.

ELECTRICAL SYSTEM AND INSTRUMENTATION

Twin diode kit for charging of two or more batteries.
 Extra instruments: Electric hour counter, fuel and water tank gauges, voltmeter and rudder indicator.
 Master switch.
 Cable harness extension.
 Instrument panel for extra instruments.
 Automatic alarm for low oil pressure and high coolant temperature.

BOAT ACCESSORIES

Electric bilge pump.
 Genuine touch-up paint.
 Oils.

CONTROLS AND STEERING SYSTEM

Volvo Penta single lever control for

speed and selection of forward/reverse, top or side-mounted.
 Neutral-position switch for Volvo Penta control.
 Push-pull control.
 Control cables.
 Steering gears.
 Steering cables.
 Ball joint and yoke for steering cables.

PROPELLER EQUIPMENT — MS2

Propeller shaft coupling.
 Flexible coupling.
 Clamping coupling.
 Propeller shafts.
 Propeller shafts sleeves.
 Propellers.

PROPELLERS — DRIVE 120S

2-blade, folding.
 2-blade I.O.R. and 3-blade.



S-405 08 Göteborg, Sweden