

NavBus  
with NavBus junction box

# Installation and Operation Manual



www.navman.com

  
NavBus

NAVMAN

# Contents

<b>1 Introducing NavBus .....</b>	<b>3</b>
<b>2 Operation .....</b>	<b>4</b>
2-1 Introduction .....	4
2-2 Principals of NavBus .....	4
2-3 Backlight group .....	4
2-4 Setting an alarm .....	4
2-5 Muting an alarm .....	4
<b>3 Parts required .....</b>	<b>5</b>
<b>4 Installation .....</b>	<b>5</b>
4-1 Position .....	5
4-2 NavBus junction box .....	6
4-3 Fitting the cover .....	6
4-4 Junction box power, NavBus data wiring .....	7
4-5 External beeper or lights (alarm) wiring .....	8
4-6 Junction box instrument wiring .....	8
4-7 Setup .....	10
<b>Appendix A - Specifications .....</b>	<b>10</b>
<b>Appendix B - How to contact us .....</b>	<b>11</b>

## Important

It is the owner's sole responsibility to install and use the instruments in a manner that will not cause accidents, personal injury or property damage. The user of this product is solely responsible for observing safe boating practices.

NAVMAN NZ LIMITED DISCLAIMS ALL LIABILITY FOR ANY USE OF THIS PRODUCT IN A WAY THAT MAY CAUSE ACCIDENTS, DAMAGE OR THAT MAY VIOLATE THE LAW.

This manual represents the NavBus as at the time of printing. Navman NZ Limited reserves the right to make changes to specifications without notice.

Governing Language: This statement, any instruction manuals, user guides and other information relating to the product (Documentation) may be translated to, or has been translated from, another language (Translation). In the event of any conflict between any Translation of the Documentation, the English language version of the Documentation will be the official version of the Documentation.

Copyright © 2002 Navman NZ Limited, New Zealand. All rights reserved. NAVMAN is a registered trademark of Navman NZ Limited.

# 1 Introducing NavBus

NavBus is a NAVMAN proprietary system that allows multiple 3100 series instruments and NAVMAN chartplotters to share data and to use a single set of transducers.

Clusters of up to four instruments are wired to a NavBus junction box which is then daisy chained via a two wire data cable to the next cluster and its NavBus junction box. Power may be run independently to junction boxes or you may choose to daisy chain the power as well.

These NAVMAN instruments can be connected by NavBus: 3100 Series family and any TRACKER 5000 Series chartplotters.

Other compatible instruments can be connected to a NavBus system by NMEA connections. NMEA is an industry standard way of connecting instruments but it requires dedicated connections between instruments. NMEA cannot be converted to NavBus and shared using NavBus.

## Example systems:

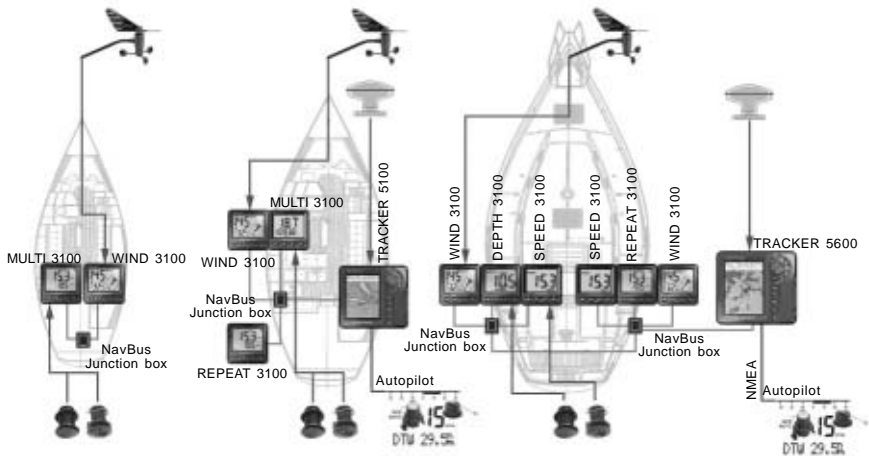

## 2 Operation

### 2-1 Introduction

Correct installation is critical to the performance of the instruments. It is vital to read this manual and the documentation that comes with the instruments before starting installation.

### 2-2 Principals of NavBus

All setup data entered into one instrument is automatically sent to all other instruments of the same type. For example:

- A transducer can be calibrated from any instrument which can display the transducer's readings.
- If the units (e.g. feet, metres, fathoms) are changed on one instrument then the same units are changed on all instruments.
- If setup data such as keel offset, speed damping or steer angle is set on one instrument then the same data is set on all instruments.

The only setup data that is not shared with other instruments is backlight group, see below.

### 2-3 Backlight group

Each instrument can be assigned to a backlight group, which is 0, 1, 2, 3, or 4. If the backlight is changed on an instrument in group 1, 2, 3 or 4 then the backlight will automatically change in the other instruments in the same group. If the backlight is changed on an instrument in group 0 then no other

instruments are affected.

Assign instruments which are mounted close together the same backlight number: 1, 2, 3 or 4. Assign isolated instruments to backlight group 0. To assign an instrument a backlight number, follow the instructions in the *Installation and setup* section of the instrument's *Installation and Operation* manual.



### 2-4 Setting an alarm

Set an alarm on any instrument that can display the alarm:

- Set the *too deep* or *too shallow* alarm on any DEPTH 3100 or MULTI 3100.
- Set the wind speed alarm on any WIND 3100.

**Note:** refer to the particular instruments operation manual for specific instructions.

### 2-5 Muting an alarm

If an alarm sounds, mute it by pressing  on any instrument which can display that alarm and which has a  key.

- Mute a too deep or too shallow alarm on any DEPTH 3100 or MULTI 3100.
- Mute the wind speed alarm on any WIND 3100.

**Note 1:** alarms can not be muted from NAVMAN's REPEAT 3100.

**Note 2:** refer to the particular instruments operation manual for specific instructions.

## 3 Parts required

NavBus junction boxes are supplied in two formats. NavBus kit and junction box only.

Parts supplied with complete NavBus kit:

- NavBus junction box.
- User manual.
- Three  $\varnothing 4 \times 16$  mm (8g x 5/8") mounting screws.
- Five 100 x 2.4 mm (4 x 3/32") cable ties.
- NavBus data cable, 10 m (33 ft) twisted pair tinned wire.
- NavBus power cable, 10 m (33 ft) twin flex tinned power cable.

**Note:** The instruments are powered from the boat's 12 V power supply. The positive line should be protected by a circuit breaker, 10 A recommended. In addition, each cluster of instruments requires a fuse in the positive power supply. NAVMAN junction boxes have the required fuses built in, otherwise fit 1 A fuses.



Parts supplied with junction box only:

- NavBus junction box.
- Manual.
- Three  $\varnothing 4 \times 16$  mm (8g x 5/8") mounting screws.
- Five 100 x 2.4 mm (4 x 3/32") cable ties.

NAVMAN accessories are available from your NAVMAN dealer.

### Part numbers:

Description	Rest of world	Europe
NavBus Kit	AA002616	43035
NavBus junction box (without cables)	AA002617	40647
10 m (33 ft) data cable for use with junction box	CB000059	43036
10 m (33 ft) power cable for use with junction box	CB000061	43037

## 4 Installation

### Warnings

The NavBus junction box has a drip-proof cover. Protect the box from water. The warranty does not cover damage caused by moisture or water entering the junction box.

Ensure that any holes that you cut will not weaken the boat's structure. If in doubt, consult a qualified boat builder.

### 4-1 Position

When fitting the NavBus junction box ensure that there is sufficient space under the overhang to allow for removal of cover.

Position the NavBus junction box in a dry place.

**Important:** Minimum clearance under overhang edge 67 mm (2 5/8")

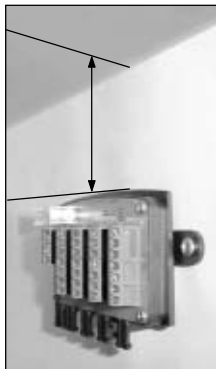

Always orient the NavBus junction box so the lugs are pointing down.

## 4-2 NavBus junction box

The NavBus junction box simplifies wiring systems of instruments. The box has one four-way terminal block for attaching power and data cables and four seven-way terminal blocks for attaching power/data cables from colour coded NAVMAN instruments.

When fitting a NavBus junction box:

- Orient the box so that the cable tie lugs point down.
- Drill 3 mm (7/64") holes for the mounting screws provided.
- Match the wire colours to the colours of the terminal block terminals.
- After installation, slide the cover back onto the box.

**Note:** Minimum clearance under overhang edge 67 mm (2 5/8")

NavBus junction box

Schematic

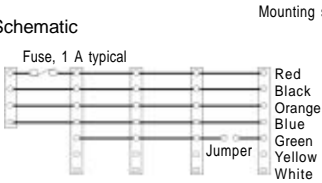

**Note:** refer to Appendix A for colour coding

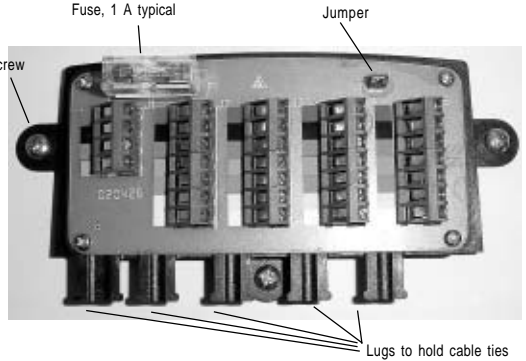

## 4-3 Fitting the cover

The NavBus junction box cover slides from the top into place.

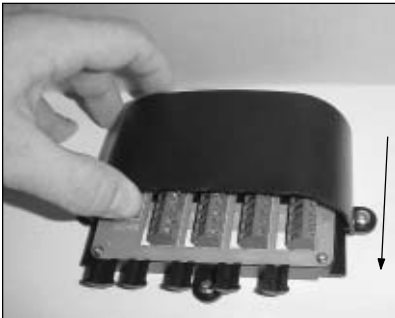

## 4-4 Junction box power and NavBus data wiring

Power wiring can be simplified by wiring power to the junction box, each instrument is powered from the NavBus junction box(es). Power is turned on and off by the instrument power switch.

### System with one junction box

No external NavBus data cable is required.

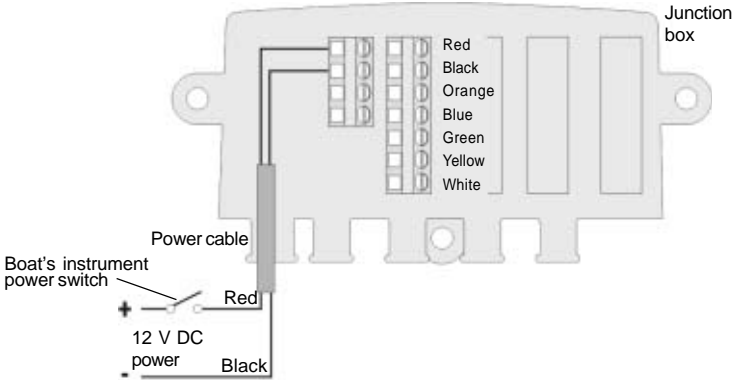

### System with more than one junction box

The power and NavBus data cables can be connected together in a star, daisy-chain or any combination of the two. The maximum total length of NavBus data cable in a system is 100 m (330 ft).

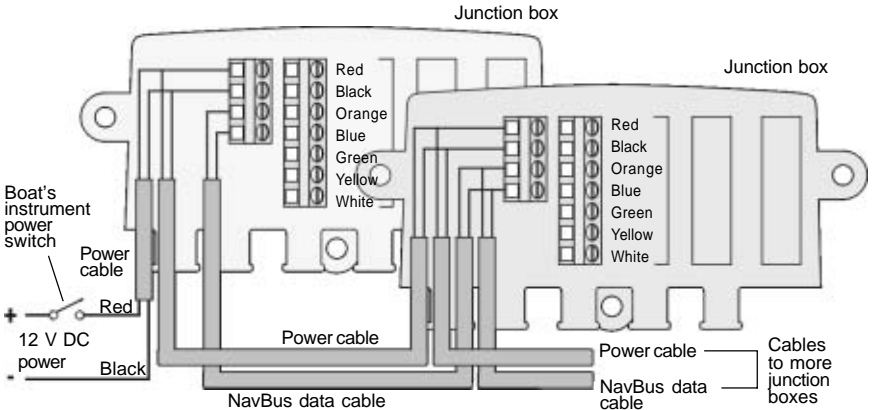

**Note:** the 10 m (33 ft) NAVMAN power and NavBus data cables can be cut if required.

## 4-5 External beeper (alarm) wiring

An alarm activates the external alarm on all instruments that are able to display that specific alarm.

Here, the external beepers (or lights) are connected at one point. It is only necessary to connect the external beepers or lights to a green terminal in one junction box.

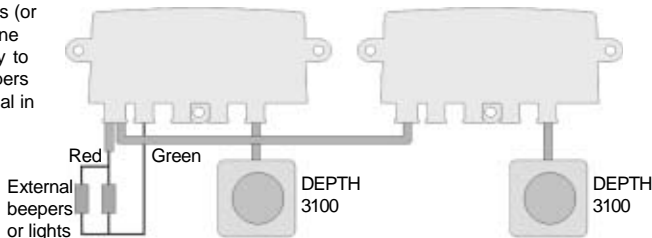

Here, two sets of external beepers or lights are connected. All beepers (or lights) will activate at the same time.

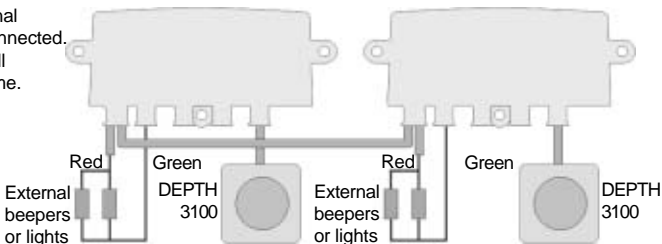

**Important:** Ensure wires are stripped and tinned.

## 4-6 Junction box instrument wiring

### SPEED 3100, DEPTH 3100, MULTI 3100 or WIND 3100

- Wire the instrument's power/data cable to one of the seven-way terminal blocks in the junction box. An instrument can be fitted to any terminal block. Wire any REPEAT 3100s to the end terminal block (see next page), otherwise ensure the jumper is fitted in the junction box. (See section 4-2)
- Wire any NMEA inputs or outputs required for the instrument to the yellow or white terminals. Ensure wires are stripped and tinned.
- Fit only one transducer of each type. For example, in the diagram below right, there is a DEPTH 3100 and a MULTI 3100, which both have depth transducer inputs. Fit **one** depth transducer, to either instrument. In some circumstances no transducer is required, refer to each instrument's *Installation and Operation* manual.

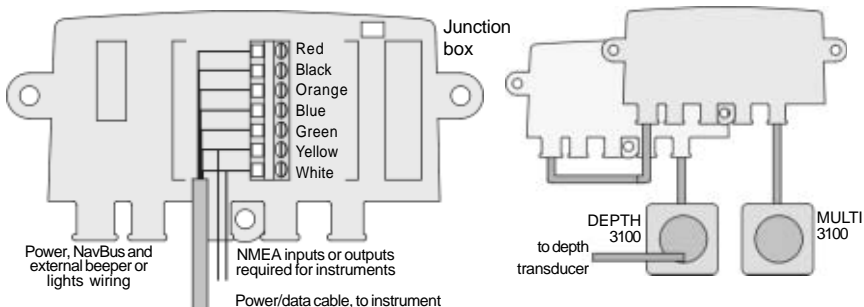



## REPEAT 3100

REPEAT 3100 is wired slightly differently from other instruments in NAVMAN's 3100 series family. The green, yellow and white wires are used for NMEA data also the REPEAT 3100 has no external beeper. Use the far right terminal block for the REPEAT 3100 and remove the jumper (indicated below). Wire any NMEA inputs to the REPEAT 3100 directly to the green, yellow or white terminals. Ensure wires are stripped and tinned.

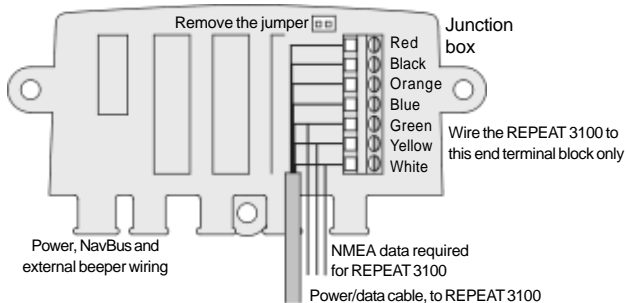

## TRACKER 5000 series chartplotters

Wire the TRACKER's power/data cable orange, blue and green wires to one of the seven-way terminal blocks in the junction box. Connect the other wires as described in the TRACKER's *Installation and Operation* manual. Wire any REPEAT 3100s to the end terminal block (see above).

Each TRACKER should have its own 1 A positive power supply fuse. If the TRACKER has the fuel option fitted, then the TRACKER's power wire should not be connected to a power supply that can be turned off.

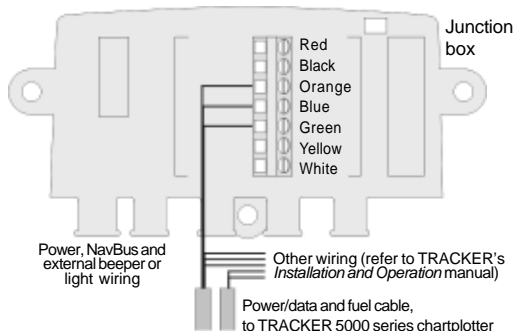

### Note:

- Instruments that are mounted close together will normally be connected to the same junction box and will be assigned the same backlight group number, (see section 1-3). Note that this is not mandatory; an instrument can be assigned any backlight group number.
- For more information about installing an instrument, refer to each instrument's *Installation and Operation Manual*. In some circumstances, no transducer is required.
- If more than one instrument requires the same NMEA input, wire this separately to each instrument's terminal block. Ensure wires are stripped and tinned.
- The yellow and white terminals are not linked together in the junction box and can be used as arbitrary connection points.
- Additional power and data cable is available from your NAVMAN dealer in 10 m (33 ft) lengths or you may supply your own.

## 4-7 Setup

Set up each instrument as described in the instrument's *Installation and Operation* manual. Assign each instrument a backlight group number (see section 2-3).

## Appendix A - Specifications

### NavBus

- Maximum total NavBus data cable length: 100 m (330 ft).

### Power Rating

- 12 V DC nominal (16.5 V maximum)
- 1 A total per junction box

### Cables

- NAVMAN NavBus data cable: Twisted pair, UL 22 AWG (diameter 0.76 mm [1/32"]), 10 m (33 ft) long.
- NAVMAN power cable: Two conductor, UL 18 AWG (diameter 1.5 mm [1/16"]), 10 m (33 ft) long.

### NAVMAN Instrument power/data cable wiring

Wire	Instrument	DEPTH 3100	SPEED 3100	WIND 3100	REPEAT 3100	5000 series chartplotter
Red	Pwr +	Pwr +	Pwr +	Pwr +	Pwr +	Pwr +
Black	Gnd	Gnd	Gnd	Gnd	Gnd	Gnd
Orange	NavBus+	NavBus+	NavBus+	NavBus+	NavBus+	NavBus+
Blue	NavBus-	NavBus-	NavBus-	NavBus-	NavBus-	NavBus- or NMEA in
Green	Ext beeper	Ext beeper	Ext beeper	Ext beeper	NMEA 3 in	Ext beeper
Yellow	NMEA_in	NMEA_in	NMEA_in	NMEA_in	NMEA 2 in	Auto power
White	NMEA_out	NMEA_out	NMEA_out	NMEA_out	NMEA 1 in	NMEA out
Brown	-	-	-	-	-	Power out, 9 V DC

- Note:**
- Shield is connected to connector pin 1, the black wire.
  - A 5000 series chartplotter has a second cable, the fuel cable. The black wire is common and the white wire is NMEA 1 input.

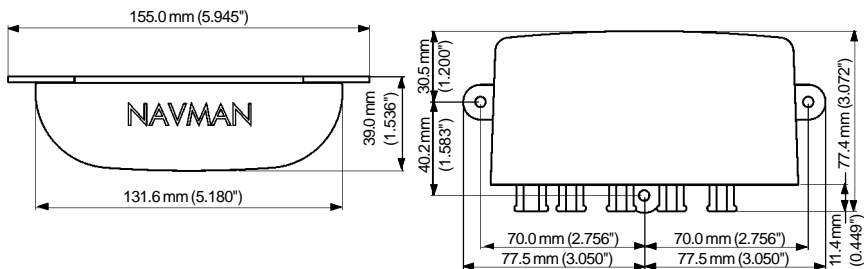

**NORTH AMERICA**  
**NAVMAN USA INC.**  
 18 Pine St. Ext.  
 Nashua, NH 03060.  
 Ph: +1 603 577 9600  
 Fax: +1 603 577 4577  
 e-mail: sales@navmanusa.com

**OCEANIA**  
**New Zealand**  
**Absolute Marine Ltd.**  
 Unit B, 138 Harris Road,  
 East Tamaki, Auckland.  
 Ph: +64 9 273 9273  
 Fax: +64 9 273 9099  
 e-mail:  
 navman@absolutemarine.co.nz

**Australia**  
**NAVMAN AUSTRALIA PTY**  
**Limited**  
 Unit 6 / 5-13 Parsons St,  
 Rozelle, NSW 2039, Australia.  
 Ph: +61 2 9818 8382  
 Fax: +61 2 9818 8386  
 e-mail: sales@navman.com.au

**SOUTH AMERICA**  
**Argentina**  
**HERBY Marina S.A.**  
 Costanera UNO,  
 Av Pte Castillo Calle 13  
 1425 Buenos Aires, Argentina.  
 Ph: +54 11 4312 4545  
 Fax: +54 11 4312 5258  
 e-mail:  
 herbymarina@ciudad.com.ar

**Brazil**  
**REALMARINE**  
 Estrada do Joa 3862,  
 Barra da Tijuca, Rio de Janeiro,  
 Brasil.  
 Ph: +55 21 2483 9700  
 Fax: +55 21 2495 6823  
 e-mail:  
 vendas@marinedepot.com.br

**Equinautic Com Imp Exp de**  
**Equip Nauticos Ltda.**  
 Av. Diario de Noticias 1997 CEP  
 90810-080, Bairro Cristal, Porto  
 Alegre - RS, Brasil.  
 Ph: +55 51 3242 9972  
 Fax: +55 51 3241 1134  
 e-mail:  
 equinautic@equinautic.com.br

**ASIA**  
**China**  
**Peaceful Marine Electronics Co. Ltd.**  
 Hong Kong, Guangzhou,  
 Shanghai, Qindao, Dalian.  
 E210, Huang Hua Gang Ke Mao  
 Street, 81 Xian Lie Zhong Road,  
 510070 Guangzhou, China.  
 Ph: +86 20 3869 8784  
 Fax: +86 20 3869 8780  
 e-mail:  
 sales@peaceful-marine.com  
 Website:  
 www.peaceful-marine.com

**Korea**  
**Kumho Marine Technology Co. Ltd.**  
 # 604-816, 3F, 1117-34,  
 Koejung-4-Dong, Saha-ku  
 Pusan, Korea  
 Ph: +82 51 293 8589  
 Fax: +82 51 294 0341  
 e-mail: info@kumhomarine.com  
 Website:  
 www.kumhomarine.com

**Malaysia**  
**Advanced Equipment Co.**  
 43A, Jalan DeJaka 2, Taman  
 Maluri, Cheras 55100, Kuala Lumpur.  
 Ph: +60 3 9285 8062  
 Fax: +60 3 9285 0162  
 e-mail: ocs@pc.jaring.my

**Singapore**  
**RIQ PTE Ltd.**  
 Blk 3007, Ubi Road 1,  
 #02-440, Singapore 408701  
 Ph: +65 6741 3723  
 Fax: +65 6741 3746  
 HP: +65 9679 5903  
 e-mail: riq@postone.com

**Thailand**  
**Thong Electronics (Thailand)**  
**Company Ltd.**  
 923/588 Sethakit 1 Road,  
 Mahachai,  
 Muang, Samutsakhon 74000,  
 Thailand.  
 Ph: +66 34 411 919  
 Fax: +66 34 422 919  
 e-mail: thonge@cscoms.com

**Vietnam**  
**Haidang Co. Ltd.**  
 16A/A1E, Ba thang hai St.  
 District 10, Hochiminh City.  
 Ph: +84 8 86321 59  
 Fax: +84 8 86321 59  
 e-mail:  
 sales@haidangvn.com  
 Website: www.haidangvn.com

**MIDDLE EAST**  
**Lebanon and Syria**  
**Letro, Balco Stores,**  
**Moutran Street, Tripoli**  
**VIA Beirut.**  
 Ph: +961 6 624512  
 Fax: +961 6 628211  
 e-mail: balco@cyberia.net.lb

**United Arab Emirates**  
**Kuwait, Oman & Saudi Arabia**  
**AMIT, opp Creak Rd.**  
**Baniyas Road, Dubai.**  
 Ph: +971 4 229 1195  
 Fax: +971 4 229 1198  
 e-mail: mksq99@email.com

**AFRICA**  
**South Africa**  
**Pertec (Pty) Ltd Coastal,**  
**Division No.16 Paarden Eiland Rd.**  
**Paarden Eiland, 7405**  
**Postal Address: PO Box 527,**  
**Paarden Eiland 7420**  
**Cape Town, South Africa.**  
 Ph: +27 21 511 5055  
 Fax: +27 21 511 5022  
 e-mail: info@kfa.co.za

**EUROPE**  
**France, Belgium and**  
**Switzerland**  
**PLASTIMO INTERNATIONAL**  
**15, rue Ingénieur Verrière,**  
**BP435,**  
**56325 Lorient Cedex.**  
 Ph: +33 2 97 87 36 36  
 Fax: +33 2 97 87 36 49  
 e-mail: plastimo@plastimo.fr  
 Website: www.plastimo.fr

**Germany**  
**PLASTIMO DEUTSCHLAND**  
**15, rue Ingénieur Verrière**  
**BP435**  
**56325 Lorient Cedex.**  
 Ph: +49 6105 92 10 09  
 +49 6105 92 10 10  
 +49 6105 92 10 12  
 Fax: +49 6105 92 10 11  
 e-mail:  
 plastimo.international@plastimo.fr  
 Website: www.plastimo.de

**Italy**  
**PLASTIMO ITALIA**  
**Nuova Rade spa, Via del Portosasso 5**  
**I-16015 CASELLA SCRIVIA (GE).**  
 Ph: +39 1096 8011  
 Fax: +39 1096 8015  
 e-mail: info@nuovarade.com  
 Website: www.plastimo.it

**Holland**  
**PLASTIMO HOLLAND BV.**  
**Industrieweg 4,**  
**2871 JE SCHOONHOVEN.**  
 Ph: +31 182 320 522  
 Fax: +31 182 320 519  
 e-mail: info@plastimo.nl  
 Website: www.plastimo.nl

**United Kingdom**  
**PLASTIMO Mfg. UK Ltd.**  
**School Lane - Chandlers Ford**  
**Industrial Estate,**  
**EASTLEIGH - HANTS S053 ADG.**  
 Ph: +44 23 8026 3311  
 Fax: +44 23 8026 6328  
 e-mail: sales@plastimo.co.uk  
 Website: www.plastimo.co.uk

**Sweden, Denmark or Finland**  
**PLASTIMO NORDIC AB.**  
**Box 28 - Lundenvägen 2,**  
**47321 HENAN.**  
 Ph: +46 304 360 60  
 Fax: +46 304 307 43  
 e-mail: info@plastimo.se  
 Website: www.plastimo.se

**Spain**  
**PLASTIMO ESPAÑA, S.A.**  
**Avenida Narcís Monturiol, 17**  
**08339 VILASSAR DE DALT,**  
**(Barcelona).**  
 Ph: +34 93 750 75 04  
 Fax: +34 93 750 75 34  
 e-mail: plastimo@plastimo.es  
 Website: www.plastimo.es

**Other countries in Europe**  
**PLASTIMO INTERNATIONAL**  
**15, rue Ingénieur Verrière**  
**BP435**  
**56325 Lorient Cedex, France.**  
 Ph: +33 2 97 87 36 59  
 Fax: +33 2 97 87 36 29  
 e-mail:  
 plastimo.international@plastimo.fr  
 Website: www.plastimo.com

**REST OF WORLD /**  
**MANUFACTURERS**  
**NAVMAN NZ Limited**  
**13-17 Kawana St. Northcote.**  
**P.O. Box 68 155 Newton,**  
**Auckland, New Zealand.**  
 Ph: +64 9 481 0500  
 Fax: +64 9 480 3176  
 e-mail:  
 marine.sales@navman.com  
 Website:  
 www.navman.com

Made in New Zealand  
MN000196 1951501B

NavBus

Lon 174° 44.535E

NAVMAN

Lat 36° 48.404'S

FC  CE