

BD35F Direct Current Compressor R134a, 12-24V DC, 10-45V DC Solar & 100-240V AC 50/60Hz

General

Code number (without electronic units)	101Z0200
Electronic unit - Standard	101N0210, 30 pcs: 101N0211
Electronic unit 12-24V DC - EMI (with metal shielding)	101N0220, 30 pcs: 101N0221
Electronic unit 12-24V DC - AEO & EMI	101N0320, 30 pcs: 101N0321
Electronic unit 10-30V DC - Solar	101N0400, 30 pcs: 101N0401
Electronic unit 20-45V DC - Solar	101N0410, 30 pcs: 101N0411
Electronic unit 12-24V DC & 100-240V AC 50/60Hz	101N0500, 36 pcs: 101N0501
Electronic unit 12-24V DC - Automotive	101N0600, 30 pcs: 101N0601
Electronic unit 12-24V DC - Automotive	101N0630, 30 pcs: 101N0631
Approved compressor - electronic unit combinations	refer to <i>Instructions</i> for 101N0xxx
Additional approvals	e4, C-Tick
Compressors on pallet	150

Application

Application	LBP/MBP/HBP	
Evaporating temperature	°C	-30 to 0 (10)
Voltage range DC	VDC	9.6 - 17 / 21.3 - 31.5
Voltage range AC	V/Hz	100 - 240 / 50 - 60
Voltage range for solar applications	VDC	10 - 30 / 20 - 45
Max. condensing temperature continuous (short)	°C	60 (70)
Max. winding temperature continuous (short)	°C	125 (135)

Cooling requirements

Application	LBP	MBP	HBP
32°C	S	S	S
38°C	S	S	S
43°C	S	S	S

Remarks on application: Fan cooling F₁ depending on application and speed.

Motor

Motor type	variable speed
Resistance, all 3 windings (25°C)	Ω 2.2

Design

Displacement	cm ³	2.00
Oil quantity (type)	cm ³	150 (polyolester)
Maximum refrigerant charge	g	300
Free gas volume in compressor	cm ³	870
Weight - Compressor/Electronic unit	kg	4.3 / 0.27 (Standard)

Standard battery protection settings (refer to 101N0xxx *Instructions* for optional settings)

Voltage	12V	24V
Cut out	VDC 10.4	22.8
Cut in	VDC 11.7	24.2

Dimensions

Height	mm	A	137
		B	135
		B1	128
		B2	73
Suction connector	location/I.D. mm angle	C	6.2 40°
		material comment	Cu-plated steel Al cap
Process connector	location/I.D. mm angle	D	6.2 45°
		material comment	Cu-plated steel Al cap
Discharge connector	location/I.D. mm angle	E	5.0 21°
		material comment	Cu-plated steel Al cap
Connector tolerance	I.D. mm	±0.09, on 5.0 +0.12/+0.20	

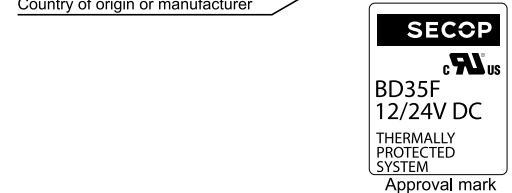
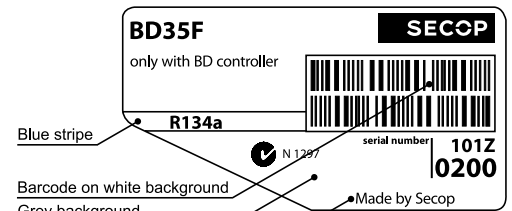

- S = Static cooling normally sufficient
- O = Oil cooling
- F₁ = Fan cooling 1.5 m/s
(compressor compartment temperature equal to ambient temperature)
- F₂ = Fan cooling 3.0 m/s necessary
- SG = Suction gas cooling normally sufficient
- = not applicable in this area

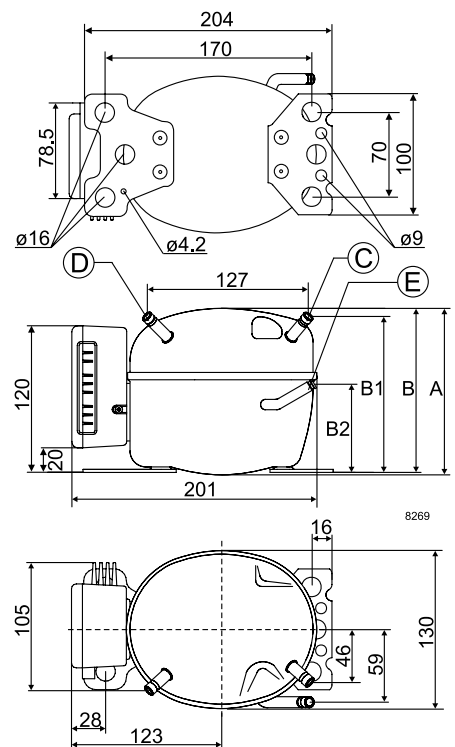

Capacity (EN 12900 Household/CECOMAF)		12V DC, static cooling										watt
rpm \ °C	-30	-25	-23.3	-20	-15	-10	-5	0	5	7.2	10	15
2,000	15.8	23.9	26.9	33.1	43.8	56.6	71.7	89.9	111	122	136	
2,500	20.2	29.9	33.5	41.2	54.6	70.7	89.7	112	139	152		
3,000	22.5	32.4	36.5	45.4	61.8	81.7	105	133				
3,500	26.2	35.9	40.4	50.5	69.8	93.6	122					

Capacity (ASHRAE LBP)		12V DC, static cooling										watt
rpm \ °C	-30	-25	-23.3	-20	-15	-10	-5	0	5	7.2	10	15
2,000	19.5	29.4	33.1	40.7	54.0	69.8	88.6	111	137	151	169	
2,500	24.9	36.8	41.3	50.7	67.3	87.1	111	139	172	189		
3,000	27.7	39.9	44.9	55.9	76.1	101	130	164				
3,500	32.2	44.2	49.7	62.2	86.0	115	150					

Power consumption		12V DC, static cooling										watt
rpm \ °C	-30	-25	-23.3	-20	-15	-10	-5	0	5	7.2	10	15
2,000	17.6	23.4	25.3	28.7	33.6	38.3	43.0	48.0	53.4	56.0	59.5	
2,500	23.3	30.9	33.3	37.8	44.1	50.2	56.2	62.3	68.7	71.7		
3,000	29.9	36.0	38.3	43.0	50.7	58.7	66.8	74.8				
3,500	36.0	42.8	45.4	50.8	59.5	68.9	78.5					

Current consumption (for 24V applications the following must be halved)												A
rpm \ °C	-30	-25	-23.3	-20	-15	-10	-5	0	5	7.2	10	15
2,000	1.5	2.0	2.1	2.4	2.8	3.2	3.6	4.0	4.5	4.67	5.0	
2,500	1.9	2.6	2.8	3.2	3.7	4.2	4.7	5.2	5.8	5.98		
3,000	2.5	3.0	3.2	3.6	4.2	4.9	5.6	6.2				
3,500	3.0	3.6	3.8	4.3	5.0	5.7	6.5					

COP (EN 12900 Household/CECOMAF)		12V DC, static cooling										W/W
rpm \ °C	-30	-25	-23.3	-20	-15	-10	-5	0	5	7.2	10	15
2,000	0.90	1.02	1.06	1.15	1.31	1.48	1.67	1.87	2.08	2.17	2.29	
2,500	0.87	0.97	1.01	1.09	1.24	1.41	1.60	1.80	2.02	2.12		
3,000	0.75	0.90	0.95	1.06	1.22	1.39	1.58	1.78				
3,500	0.73	0.84	0.89	1.00	1.17	1.36	1.55					

COP (ASHRAE LBP)		12V DC, static cooling										W/W
rpm \ °C	-30	-25	-23.3	-20	-15	-10	-5	0	5	7.2	10	15
2,000	1.10	1.25	1.31	1.42	1.61	1.82	2.06	2.31	2.57	2.70	2.84	
2,500	1.07	1.19	1.24	1.34	1.53	1.74	1.97	2.23	2.50	2.63		
3,000	0.93	1.11	1.17	1.30	1.50	1.72	1.95	2.20				
3,500	0.89	1.03	1.09	1.23	1.44	1.68	1.91					

Test conditions	EN 12900/CECOMAF	ASHRAE LBP
Condensing temperature	55°C	54.4°C
Ambient temperature	32°C	32°C
Suction gas temperature	32°C	32°C
Liquid temperature	no subcooling	32°C

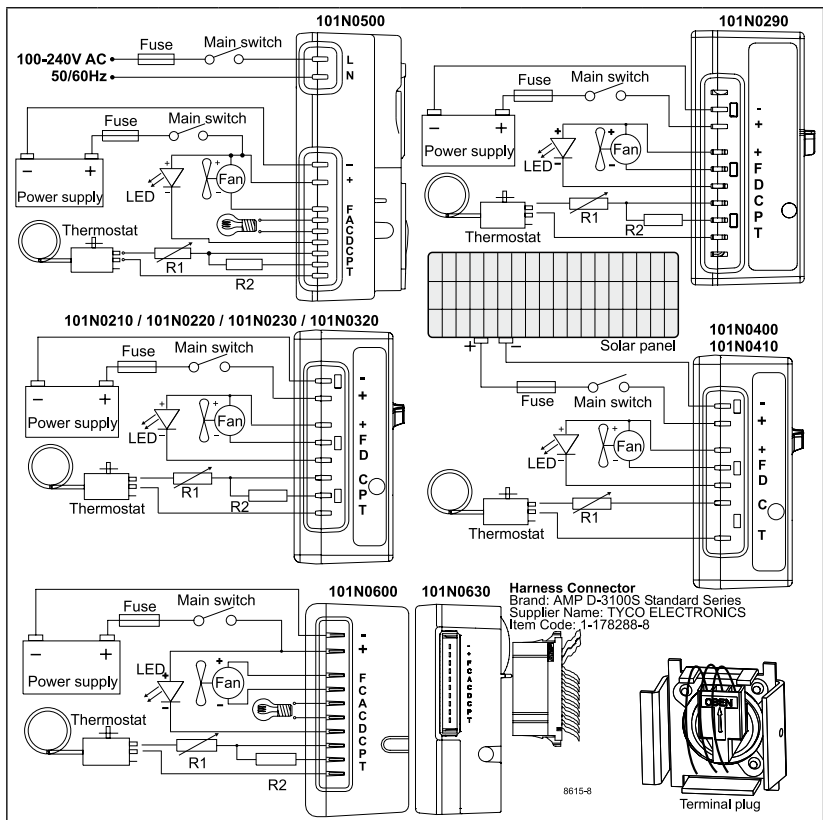

Operational errors shown by LED (optional)	
Error code	Error type
5	Thermal cut-out of electronic unit (If the refrigeration system has been too heavily loaded, or if the ambient temperature is high, the electronic unit will run too hot).
4	Minimum motor speed error (If the refrigeration system is too heavily loaded, the motor cannot maintain minimum speed at approximately 1,850 rpm).
3	Motor start error (The rotor is blocked or the differential pressure in the refrigeration system is too high (>5 bar)).
2	Fan over-current cut-out (The fan loads the electronic unit with more than 1A _{peak}).
1	Battery protection cut-out (The voltage is outside the cut-out setting).

Compressor speed			
Electronit unit	Resistor (R1) [Ω] calculated values	Motor speed [rpm]	Control circuit current [mA]
101N0210	0	2,000	5
101N0220	277	2,500	4
101N0500	692	3,000	3
101N0600	1523	3,500	2
101N0320	0	AEO	6
101N0400	173	2,000	5
101N0410	450	2,500	4
101N0410 with AEO	865	3,000	3
	1696	3,500	2

In AEO (Adaptive Energy Optimizing) speed mode the BD compressor will always adapt its speed to the actual cooling demand.

Wire Dimensions DC						
Cross section	Size		Max. length* 12V operation		Max. length* 24V operation	
	[mm ²]	AWG [Gauge]	[m]	[ft.]	[m]	[ft.]
2.5	12	12	2.5	8	5	16
4	12	12	4	13	8	26
6	10	10	6	20	12	39
10	8	8	10	33	20	66

*Length between battery and electronic unit

Wire Dimensions AC
Cross section min. 0.75 mm² or AWG 18

Accessories for BD35F	Code number
Bolt joint for one comp.	Ø:16 mm 118-1917
Bolt joint in quantities	Ø:16 mm 118-1918
Snap-on in quantities	Ø:16 mm 118-1919
Remote kit (without cable)	105N9210

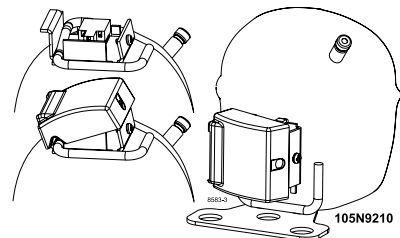

AC line cord UL approved	105N9520
AC line cord VDE approved	105N9530
DC usage:	Automobile fuse 12V: 15A DIN 7258 24V: 7.5 A
	Main switch min. 20A
AC usage:	Fuse, 100-240V min. 4A Main switch min. 6A

Not deliverable from Secop

Danfoss can accept no responsibility for possible errors in catalogues, brochures and other printed material. Danfoss reserves the right to alter its products without notice. This also applies to products already on order provided that such alterations can be made without consequential changes being necessary in specifications already agreed. All trademarks in this material are property of the respective companies. Danfoss and the Danfoss logotype are trademarks of Danfoss A/S. All rights reserved.