



QK-A027 Wireless AIS+GPS Receiver

With SeaTalk* Converter

Features

- Two independent receivers monitoring both AIS channels (161.975MHz & 162.025MHz) and decoding both channels simultaneously
- Sensitivity up to -106 dBm@30% PER
- Up to 45 nautical miles receiving range
- Powered by the SeaTalk bus (<120mA@12.0V)
- NMEA 0183 message output through WiFi, USB and RS422
- Configurable baud rates: (4.8, 9.6, 38.4k input and output)
- Simultaneous wireless and USB output.
- The internal WiFi access point connects up to 4 devices simultaneously
- Ad Hoc and Station operating modes
- SeaTalk to NMEA 0183 protocol converter
- Built-in GPS to provide positional data
- Combines GPS and AIS messages with NMEA 0183 and outputs as a seamless stream of data
- BNC connector for 50 Ohm VHF antenna
- Powered SMA connector for 50 Ohm GPS antenna
- Plug & Play connectivity with chart plotters and PCs
- Compatible with Windows, Mac, Linux, Android and iOS (Initial Configuration must be completed using Windows software.)
- This device connects to NMEA 0183 and is compatible with RS422 output devices. NMEA 0183-RS232 devices can connect to our device by using the Garmin Bridge (QK-AS03).
- This device does not come pre-loaded with map data. We advise using openCPN for map data. Some iOS apps may charge for map use.



Designed in UK



* Seataalk™ is a family of proprietary maritime communications protocols developed by Raymarine

Limited warranty

Quark-elec warrants this product to be free from defects in materials and manufacture for one year from the date of purchase. Quark-elec will, at its sole option, repair or replace any components that fail in normal use. Such repairs or replacement will be made at no charge to the customer for parts and labour. The customer is, however, responsible for any transportation costs incurred in returning the unit to Quark-elec. This warranty does not cover failures due to abuse, misuse, accident or unauthorized alteration or repairs. A returns number must be given before any unit is sent back for repair.

The above does not affect the statutory rights of the consumer.

Disclaimer

This product is designed to aid navigation and should be used to augment normal navigational procedures and practices. It is the user's responsibility to use this product prudently. Neither Quark-elec, nor their distributors or dealers accept responsibility or liability either to the product user or their estate for any accident, loss, injury or damage whatsoever arising out of the use or of liability to use this product.

Accuracy of this manual

Quark-elec AIS receivers may be upgraded from time to time and future versions may therefore not correspond exactly with this manual. The manufacturer of this product disclaims any liability for consequences arising from omissions or inaccuracies in this manual and any other documentation provided with this product.

Document history

Issue	Date	Changes / Comments
1.0	31-10-2017	Initial release

Order Information

Part No	Description
QK-A024	Dual channel AIS wireless receiver without built-in GPS receiver
QK-A026	Dual channel AIS wireless receiver with built-in GPS receiver
QK-A027	Dual channel AIS wireless receiver with built-in GPS receiver with SeaTalk converter

Contents

Contents.....	3
1 Introduction.....	4
2 Hardware.....	5
3 Installation & Operation.....	8
3.1 Mounting.....	8
3.2 Power up.....	8
3.3 USB connection.....	8
3.4 WiFi connection.....	10
3.5 NMEA output connection.....	11
3.6 SeaTalk connection.....	11
4 Working with OpenCPN.....	13
5 Antenna.....	15
6 Specification.....	15

1 INTRODUCTION

The marine Automatic Identification System (AIS) is a location and vessel information reporting system. It allows vessels equipped with AIS to automatically and dynamically share and regularly update their position, speed, course and other information such as vessel identity with similarly equipped vessels. Position is derived from the Global Positioning System (GPS) and communication between vessels is by Very High Frequency (VHF) digital transmissions. There are a number of types of AIS device, like Class A transceivers, Class B transceivers, AIS base stations, Aids to Navigation (AtoN) and AIS receivers.

QK-A027 is a compact dual channel, VHF AIS receiver and is able to receive information from both AIS frequencies simultaneously. It includes an integrated GPS module that can track up to 22 satellites on 66 channels. It can also combine one external Seataalk¹ data source with GPS and AIS messages. This single data stream is then transmitted synchronously via WiFi, USB and RS422.

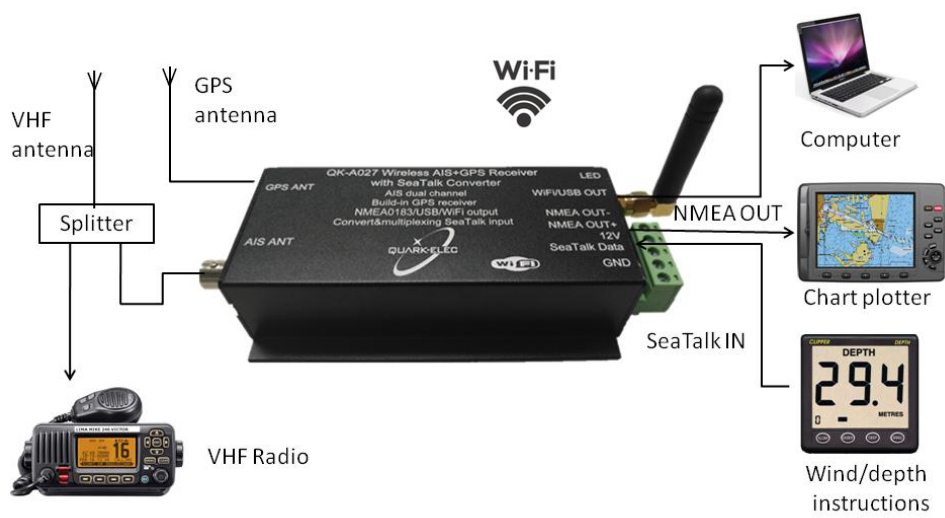

Figure 1 System diagram

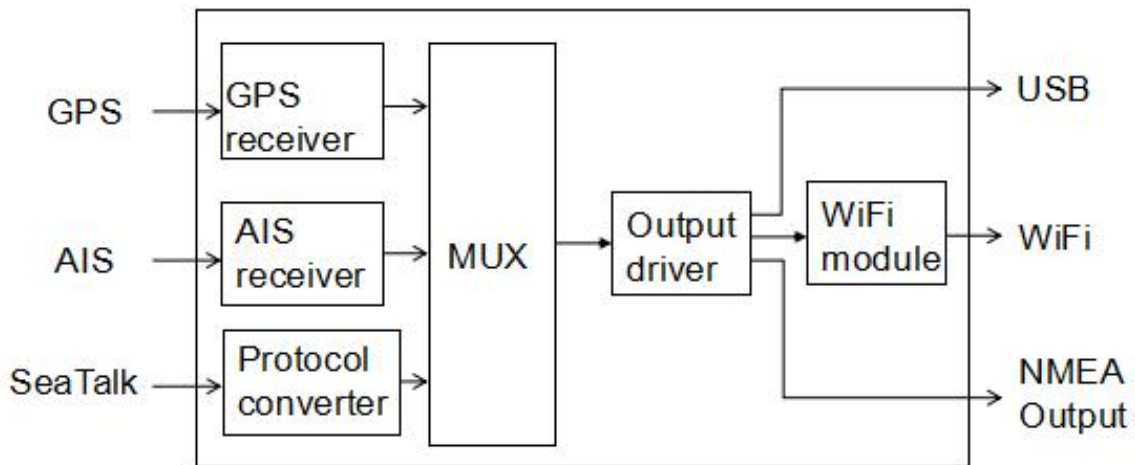

Figure 2 QK-A027 Function diagram

2 HARDWARE

The QK-A027 is aimed at the small-commercial, leisure and fishing boat markets. Connected to an on board PC running compatible software, or a chart plotter, AIS data transmitted from ships within range can be displayed on the screen enabling the skipper or navigator to visualize the traffic within VHF range. Using QK-A027 can enhance safety at sea by providing proximity, size and directional information from other vessels, improve safety and efficiency in navigation and help protect the marine environment.

Although QK-A027 comes with an extruded aluminum enclosure to shield it from external RF interference, it should not be fitted close to generators or compressors (e.g. refrigerators) as they can generate substantial RF noise. It is designed to be installed in a protected indoor environment. So generally a suitable placement of QK-A027 is together with other types of navigation equipment and the PC or chart plotter that will be used to display the output data. The following figure shows an overview of the QK-A027.



Figure 3 Overview of QK-A027

QK-A027 has the following electrical connections/indicators:

- USB connector. A micro USB connector outputs the NMEA messages. It can also be used for adjusting parameters using the GUI Configuration software.
- NMEA 0183 output connectors. QK-A027 can be connected to other AIS compatible equipment, like wind/depth or heading sensors, via the NMEA outputs. QK-A027 sends out NMEA 0183 messages via WiFi, USB and NMEA outputs simultaneously.
- GPS antenna connector. Standard powered SMA female 50 Ohm connector to connect with an active GPS antenna.
- AIS antenna connector. Standard BNC female 50 Ohm connector. An active VHF antenna splitter is required if one VHF antenna is shared by QK-A027 and VHF voice radio.
- SeaTalk input connector. The SeaTalk port has 3-Pin terminals for connection to the SeaTalk bus. Ensure the connection is correct before powering up. An incorrect connection could damage the QK-A027 and other devices on the SeaTalk Bus.
- LED lights. QK-A027 features three LEDs which indicate power, AIS and GPS status respectively. Three LEDs turn on and then off after initialization. When operating, these LEDs flash as below:

Power: Top LED flashes at 3 second intervals.

AIS: Middle LED Flashes for each valid AIS message received.

GPS: Bottom LED Flashes every second while receiving a valid message

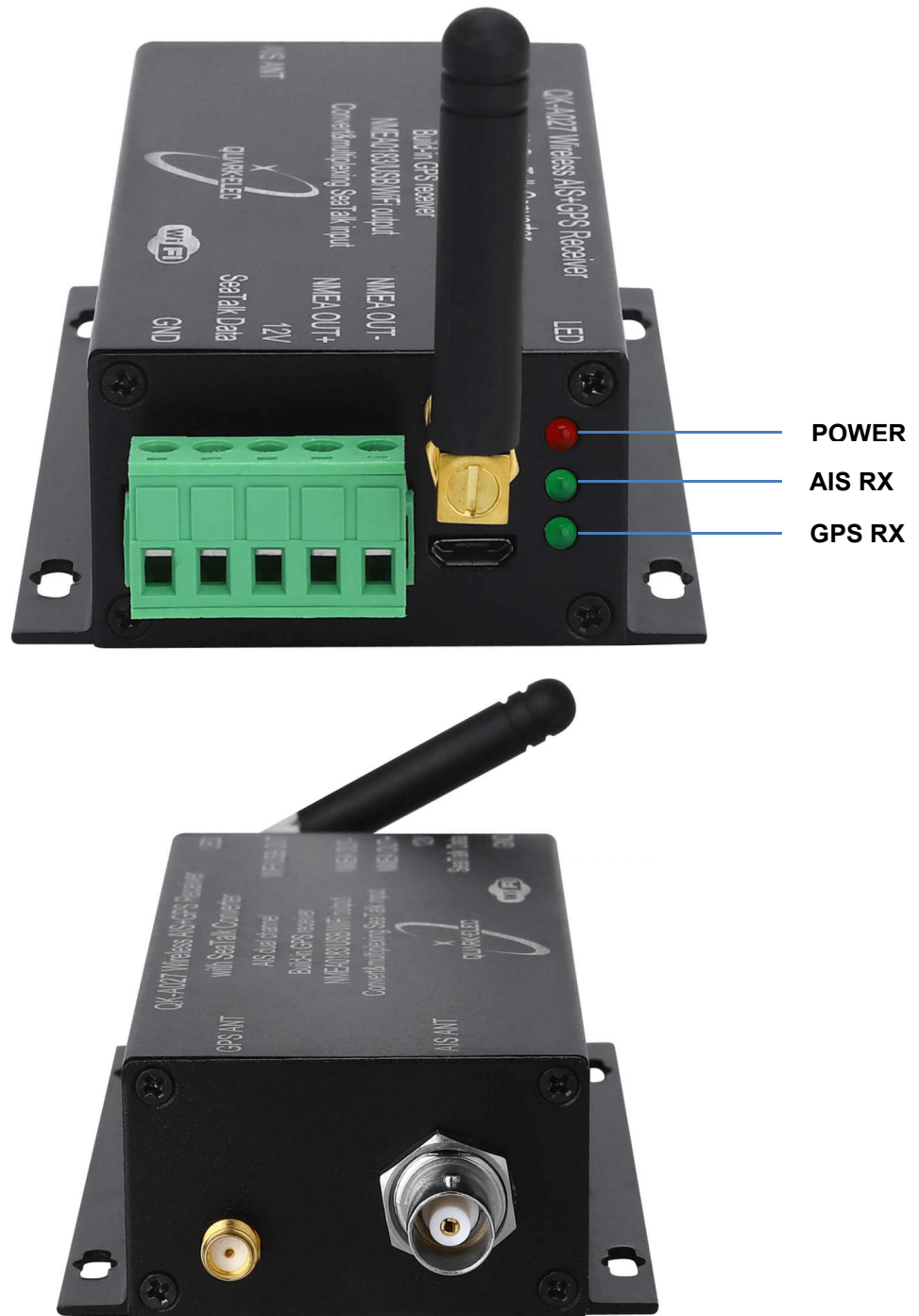

Figure 5 GPS and AIS antenna connector

3 INSTALLATION & OPERATION

3.1 Mounting

QK-A027 is designed to be securely mounted to a suitable bulkhead or shelf in an indoor environment and needs to be placed where it is well protected from humidity and water.

QK-A027 is **not** supplied with a VHF antenna as the type of antenna and cable requirements differ from vessel to vessel. A suitable VHF antenna will need to be connected before the receiver will operate fully.

3.2 Power up

QK-A027 runs on 12.0V DC and is powered through the SeaTalk interface, this allows a much cleaner supply and a concomitant improvement in signal reception.

3.3 USB connection

QK-A027 is supplied with a micro USB connector which the NMEA 0183 data can output through. This USB connector can be linked directly to a USB port on the PC or other mobile devices via the supplied cable. When the USB cable is connected, the LEDs will light up, this does not mean the module is sufficiently powered, functional power must come from the SeaTalk bus or the unit will not work.

To enable the USB data connection of QK-A027 to other devices, related hardware drivers may be needed dependent on system requirements.

For Windows 8, 7, Vista and XP, the driver can be found on the CD in the packing box or can be downloaded from the Quark-elec website at:

<https://www.quark-elec.com/product/qk-a027-wireless-ais-gps-receiver-with-seatalk-converter/>

QK-A027 registers itself to the computer as a virtual serial port.

No drivers are required on Windows 10. A new COM port will automatically show up in the device manager after plug in.

For Mac OS X, QK-A027 will be recognized and shown as a USB modem. The ID can be checked with the following steps:

--- After plugging QK-A027 into a USB port, launch Terminal.app.

--- Type `ls /dev/*usb*`

--- Mac system will return a list of USB devices. QK-A027 will display as - `"/dev/tty.usbmodemXYZ"` where XYZ is a number. Nothing further needs to be done if it is listed.

No driver is required for Linux. When plugged into the computer, QK-A027 will show up as a USB CDC device on `/dev/ttyACM0`.

Quark-Elec Manual

The USB connection status can always be checked with a terminal monitor application like Putty or HyperTerminal. Ensure that the COM port is set at 38400bps, 8, N and 1 as shown below using HyperTerminal on Windows as an example to illustrate this process. Connect QK-A027 to the computer, follow the instructions to install the driver if required. After the driver is installed, run the Hardware Manager and check the COM interface number.

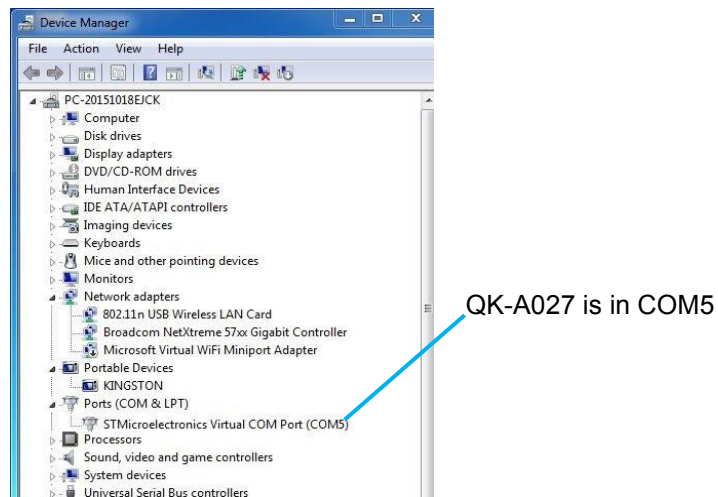

Figure 6 Check COM port

Run HyperTerminal, ensure that the COM port is set at 38400bps, 8, N and 1.

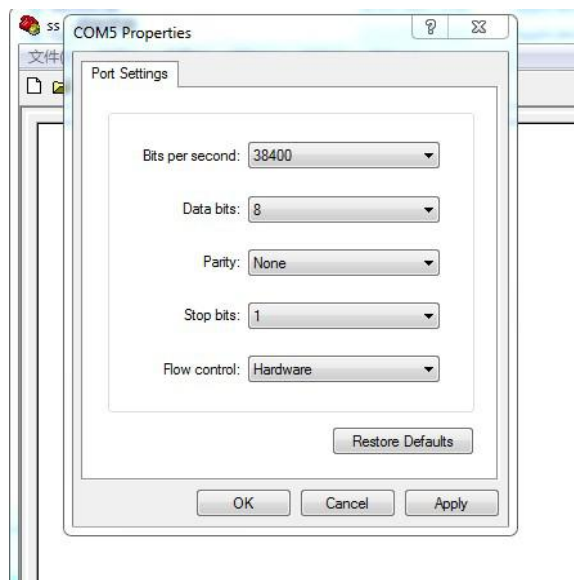

Figure 7 Setting on HyperTerminal

If all the above is set up correctly, similar AIS messages to the examples below should be shown.

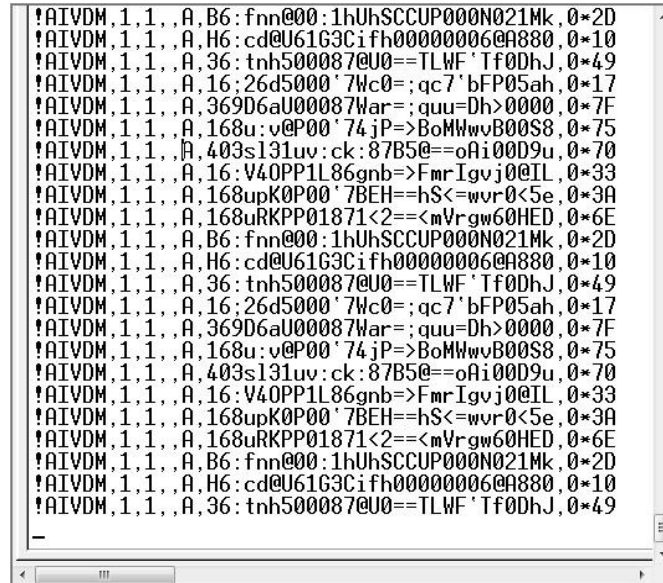

Figure 8 Display on HyperTerminal

3.4 WiFi connection

15 seconds after QK-A027 has been powered up, the operator should be able to scan and find a WiFi network (SSID) similar to 'QK-A027xxxx' using WiFi enabled devices such as computers, mobile phones or tablets.

Connect the device/s to 'QK-A027xxxx' with '88888888' as the default password. Set the protocol as 'TCP', IP address as '192.168.1.100' and the port number as '2000' in the chart software.

Item	Setting
SSID	Similar to 'QK-A027xxxx'
Protocol	TCP
IP address	192.168.1.100
Port	2000

With the above settings, wireless connection should be set and the operator will be able to receive the AIS messages through the chart software. the operator can always check the wireless connection with TCP/IP port monitoring software as shown below:

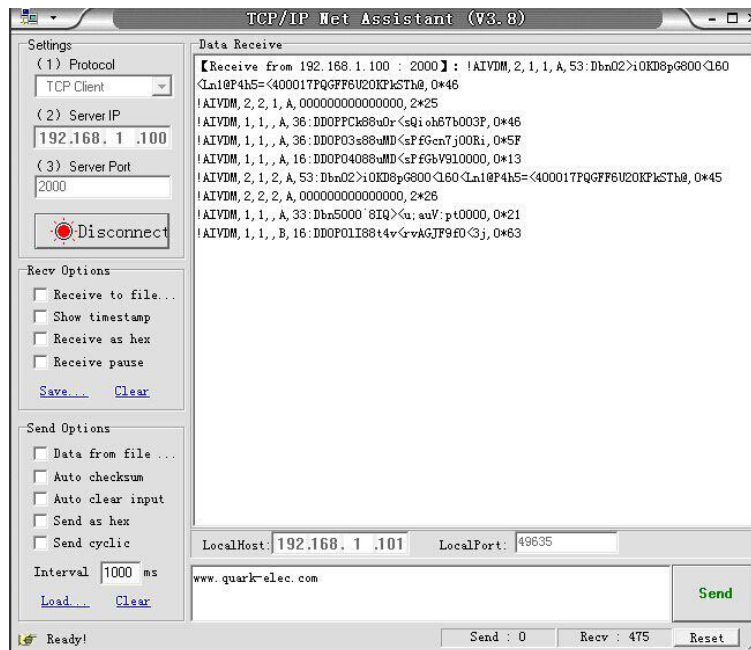

Figure 9 TCP/IP setting check

Note: In Ad-hoc mode, the IP address should not be changed and the password should be between 8 to 12 characters.

QK-A027 can also be connected in Station Mode by changing these parameters to those of your Wireless Access Point. The Configuration Software (GUI) can be used to adjust these settings, including baud rates and WiFi settings. You can download the software here:

https://quark-elec.com/doc/QE_MUX_configTool.zip

Detailed instructions on how to use the Configuration software are available here:

https://www.quark-elec.com/doc/QK-A0xx_GUI_application_note.pdf

3.5 NMEA output connection

The NMEA0183 connector provides the links to a chart plotter and other instruments. It consists of two differential output connectors. The output operates at a baud rate of 38400bps. The connected chart plotter should be configured at this rate to receive the proper data.

The built-in multiplexer takes the SeaTalk data together with GPS and AIS messages, and combines them into a single stream before outputting as NMEA at 38400bps.

3.6 SeaTalk connection

The SeaTalk port has 3-Pin terminals for connection to the SeaTalk bus. Ensure the connection is correct before powering up. Incorrect connection could damage the QK-A027 and other devices on the SeaTalk Bus. QK-A027 utilises the power supply from the SeaTalk bus.

Quark-Elec Manual

When a SeaTalk message is received, QK-A027 checks if the message is recognised and should be processed. When the message is recognized by the SeaTalk messages table, the message is extracted, stored and converted to an NMEA sentence. Any unknown datagram is ignored. These converted NMEA messages are then combined with GPS and AIS messages internally. This function allows a SeaTalk instrument to communicate on an NMEA network. Only one SeaTalk input is needed since the SeaTalk bus is a single-cable system that connects all the instruments together through one cable. SeaTalk to NMEA converter in the QK-A027 works in one direction only. No NMEA sentences are converted into SeaTalk, the multiplexer just listens on the SeaTalk bus.

Supported SeaTalk Datagrams		
SeaTalk	NMEA	Description
00	DBT	Depth below transducer
10	MWV	Wind angle, (10 and 11 combined)
11	MWV	Wind speed, (10 and 11 combined)
20	VHW	Speed through water, includes heading when Present
21	VLW	Trip mileage (21 and 22 combined)
22	VLW	Total mileage (21 and 22 combined)
23	MTW	Water temperature
25	VLW	Total and Trip mileage
26	VHW	Speed through water, includes heading when present
27	MTW	Water temperature
50	---	GPS latitude, value stored
51	---	GPS longitude, value stored
52	---	GPS speed over ground, value stored

53	RMC	Course over ground. RMC sentence is generated from stored values from other GPS related datagrams.
54	---	GPS time, value stored
56	---	GPS date, value stored
58	---	GPS lat/long, values stored
89	HDG	Magnetic heading, including variation (99)
99	---	Magnetic variation, value stored

The table shows that not all datagrams result in an NMEA 0183 sentence. Some datagrams are only used to retrieve data, which is combined with data from other datagrams to be able to create one NMEA 0183 sentence.

4 WORKING WITH OPENCNP

OpenCPN is free software that can be used to view concise chart plotter and navigation information, It is available for use on both Windows and the MAC OSX system from:

<http://opencpn.org/ocpn/download>

The following is a sample setting for the OpenCPN plotter. COM2 was set as the QK-A027 input and COM1 is used for other standard serial port, e.g.depth instruction.

Other software is available such as SeaClear, PolarNavy, PolarView. They all have similar settings.

<http://www.sping.com/seaclear/>

<http://www.polarnavy.com/>

<http://www.polarnavy.com/main/prod1>

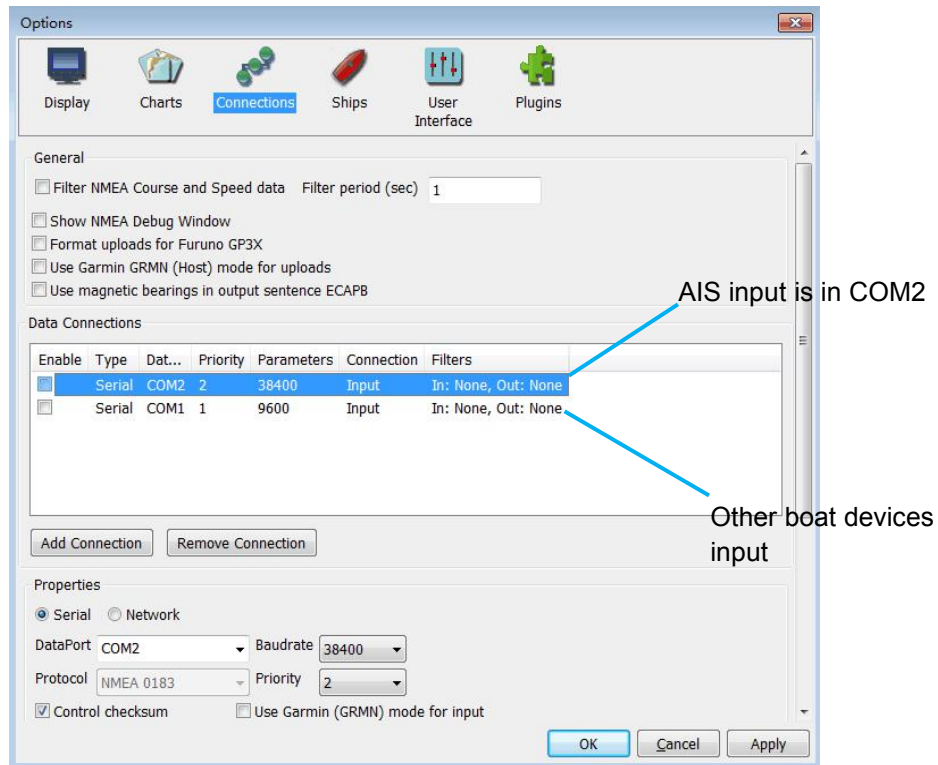

Figure 10 Serial port setting on OpenCPN

For Wifi connection, 'Network' rather than 'Serial' needs to be selected in 'Connections->Properties' and the following settings need to be input.

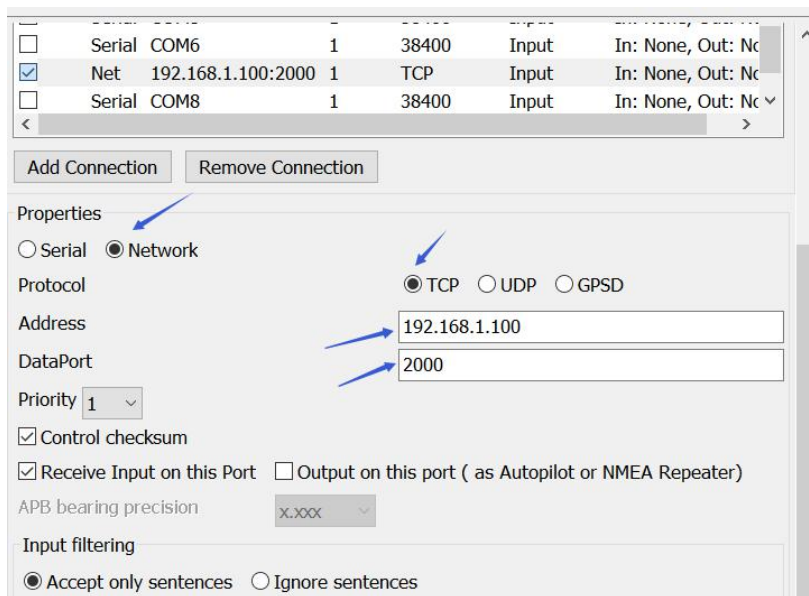

Figure 11 WiFi setting on OpenCPN

5 ANTENNA

AIS communication systems use frequencies in the maritime VHF band, which is considered to be 'line of sight' radio. This means that if the QK-A027 antenna cannot 'see' the antennas of other vessels, the AIS signals from vessels will not reach QK-A027. In practice, this is not a strict requirement, a few buildings and trees between them will be fine. Large obstacles such as hills and mountains, on the other hand, will significantly degrade the AIS signal

To have the best possible receiving range, the AIS antenna should be placed as high as possible with a relatively clear view of the horizon. Large obstructions might shade the AIS radio communication from certain directions, giving uneven coverage.

AIS communication system frequencies are close to the duplex channels used for marine communication, so the antenna should be separated as much as possible (ideally at least 3.0 meters) from the voice communication VHF antenna to avoid unnecessary adjacent channel interference. Best separation is achieved by installing the antennas over each other or on separate sides of the mast. If an existing VHF transmitting antenna is used to receive AIS signals, proper separation equipment (e.g., an active VHF antenna splitter) should be applied.

6 SPECIFICATION

Item	Specification
Frequency bands	161.975MHz & 162.025MHz
Operating temperature	-25°C to +80°C
Storage temperature	-25°C to +85°C
DC supply	12.0V(+/-0.5V)
Average supply current (typical quiescent)	120mA
Maximum supply current(during SMS transceiver activity)	160mA
AIS receive sensitivity	-105dBm@30%PER
GPS receiver sensitivity	-162dBm
NMEA data format	ITU/ NMEA 0183 format
SeaTalk input data rate	4.8kbps
NMEA output data rate	38.4kbps
WiFi mode	Station mode on 802.11 b/g/n
Security	WPA/WPA2
Network Protocols	TCP.



Quark-Elec Manual

For more technical information and other enquiries, please go to the Quark-elec forum at:

<https://quark-elec.com/forum/>

For sales and purchasing information, please email us: info@quark-elec.com



Quark-elec (UK)

Unit 7, The Quadrant

Newark Close

Royston, UK

SG8 5HL